

user manual

K-BUS® KNX Gateway for IR _V1.2

KNX Gateway for IR, Flush mounted, 2-Fold

BTIRF-02/00.2

KNX Gateway for IR, Ceiling

BTIRC-01/00.2

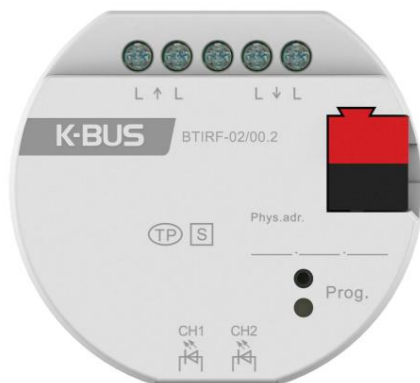

KNX/EIB Home and Building Control System

Attentions

1. Please keep devices away from strong magnetic field, high temperature, wet environment;



2. Do not fall the device to the ground or make them get hard impact;



3. Do not use wet cloth or volatile reagent to wipe the device;



4. Do not disassemble the devices.

Contents

| | |
|---|----|
| Chapter 1 General | 1 |
| Chapter 2 Technical Data | 3 |
| 2.1 KNX Gateway for IR, Flush mounted, 2-Fold (BTIRF-02/00.2) | 3 |
| 2.2 KNX Gateway for IR, Ceiling (BTIRC-01/00.2) | 4 |
| Chapter 3 Dimension and Connection Diagram | 5 |
| 3.1 Dimension diagram | 5 |
| 3.2 Connection diagram | 6 |
| Chapter 4 Project design and Application | 7 |
| Chapter 5 Parameter setting description in the ETS | 9 |
| 5.1 Parameter window "DCA Note" | 9 |
| 5.2 Parameter window "General setting" | 10 |
| 5.3 Parameter window "Channel x" (x=1, 2) | 12 |
| 5.3.1. Parameter window "Universal IR control setting" | 12 |
| 5.3.2. Parameter window "Air-condition control setting" | 15 |
| 5.4 Parameter window "Sequence mode setting" | 23 |
| 5.5 Parameter window "Current detect setting" | 26 |
| Chapter 6 Communication Object Description | 28 |
| 6.1 "General setting" communication object | 28 |
| 6.2 "Universal IR code control" communication object | 29 |
| 6.3 "Air-condition control" communication object | 30 |
| 6.4 "Sequence mode" communication object | 32 |
| 6.5 "Current detect" communication object | 32 |

Chapter 1 General

KNX Gateway for IR is mainly used to store the IR code learned by the IR learner. Then sending the control telegrams to make KNX Gateway for IR send IR code via KNX device, to perform actions by controlling IR remote control devices such as fan, Air-condition, TV, DVD and etc.

KNX Gateway for IR includes KNX Gateway for IR, Flush mounted, 2-Fold (BTIRF-02/00.2) and KNX Gateway for IR, Ceiling (BTIRC-01/00.2). Each product has 2 IR emission channels which can be set as universal IR control or Air-condition control, up to store 300 different IR codes. In addition, KNX Gateway for IR, Flush mounted also has 1 fold current detection function, which can confirm the on or off status of controlled device via current status, and avoid false triggers if On and Off are controlled by the same IR code. KNX Gateway for IR, Ceiling supports for a 360° all-round emitted.

Meanwhile, we provide configuration software tool (KNX Gateway for IR configuration) or DCA for KNX Gateway for IR, is used for auxiliary IR code to learn, test, configure, and download the IR code to the device. KNX bus can control IR device after ETS configuration. **Note: KNX Gateway for IR configuration is PC software running independently in the computer, and DCA is an APP plug-in of ETS. The detailed operation please refer to the tool user manual.**

In addition, auxiliary tool-- IR Learner (BTIL-01/00.2) is connected with PC by USB, is used for learning the button function codes of IR remote control devices, such as Fan, Air-condition, TV and etc., and saved them in configuration tool. The IR learner can learn more than 95% IR remote control devices in the market. The learning process is realized via operating configuration software tools, and at the same time the IR detector of remote controller should get as close as possible to the IR learner's, to avoid learn failure. The IR learner has both IR receiving and sending function, test and verify whether the learned function code is correct.

This manual provides specific technical information about KNX gateway for IR for users, as well as assembly and programming details, and explains how to use the device by the application examples.

The functions of KNX gateway for IR are summarized as follows:

- ÿ Support Universal IR control, up to 30 IR codes can be configured for each channel
- ÿ Support Air-condition control, up to 266 IR codes can be configured, control functions include:
 - ON/OFF, temperature, mode, fan speed, swing
- ÿ Support current detection function, up to 10A, can be associated with the transmitting channel (**Only KNX Gateway for IR, Flush mounted supports the function**)
- ÿ Support up to 16 sequence controls, each sequence supports up to 4 IR commands to be transmitted by step
- ÿ Support transmit with several times or delay time

KNX Gateway for IR, Flush mounted and KNX Gateway for IR, Ceiling only powered from KNX bus. It is available to assign the physical address and configure the parameters by engineering design tools ETS with .knxprod (support edition ETS5.7 or higher).

Chapter 2 Technical Data

2.1 KNX Gateway for IR, Flush mounted, 2-Fold (BTIRF-02/00.2)

The extremely compact design enables the KNX gateway for IR to be inserted into a conventional 80mm or 86mm wiring box.

Attention: the Infrared emitter of the KNX gateway for IR must be installed in range that the IR device can detect normally, to avoid no action.

| | | |
|------------------------------|--|--|
| power supply | bus voltage | 21-30V DC, via the KNX bus |
| | bus current | <6.5mA, 24V <6mA, 30V |
| | bus consumption | <180mW |
| | dynamic current | <9.5mA, 24V <8mA, 30V |
| Current Detection | current detection range | 50mA-10A |
| | Current detection accuracy | 50mA-500mA ±20mA 500mA-10A ±5% |
| Output | channel | 2 independent channels |
| | Max. transmitting distance | 2m |
| | IR wavelength | 940nm |
| | IR emission receiving angle | <45° |
| connection | KNX | Bus connection terminal (Red/Black) |
| | load | Screw terminals, Wire Range, Multi-core 0.2-1.5mm ² |
| | (For Current Detection) IR detector extension cable | Single core 0.2-2.5mm ² , Torque 0.4Nm <10m |
| Operation and display | Programming button and Red LED | For assigning the physical address |
| | Green LED flashing | For displaying application layer running normally |
| Temperature | Operation | - 5 °C ... 45 °C |
| | storage | - 25 °C ... 55 °C |
| | Transportation | - 25 °C ... 70 °C |
| Environment | Humidity | <93%, except dewing |
| Installation | Mounting | In wiring box, 80x80mm or 86x86mm |
| dimension | | 53x23.5mm |
| Weight | | 0.04kg |

2.2 KNX Gateway for IR, Ceiling (BTIRC-01/00.2)

The extremely compact design enables the KNX Gateway for IR to be mounted in the ceiling. 360° full direction transmitting.

Attention: the Infrared emitter of the KNX gateway for IR must be installed in range that the IR device can detect normally, to avoid no action.

| | | |
|------------------------------|--------------------------------|---|
| power supply | operation voltage | 21-30V DC, via the KNX bus |
| | bus current | <8mA, 24V |
| | | <7mA, 30V |
| | bus consumption | <210mW |
| | dynamic current | <14mA, 24V |
| <12mA, 30V | | |
| Output | IR wavelength | 940nm |
| | radius distance | <3m |
| Installation | Height | <4m |
| Connections | KNX | Bus connection terminal(Red/Black) |
| Operation and display | Programming button and Red LED | For assigning the physical address |
| | Green LED flashing | For displaying application layer running normally |
| Temperature | Operation | - 5 °C ... 45 °C |
| | storage | - 25 °C ... 55 °C |
| | Transportation | - 25 °C ... 70 °C |
| Environment | Humidity | <93%, except dewing |
| dimension | 91 × 76 × 82.25mm | |
| Weight | 0.05kg | |

Chapter 3 Dimension and Connection Diagram

3.1 Dimension diagram

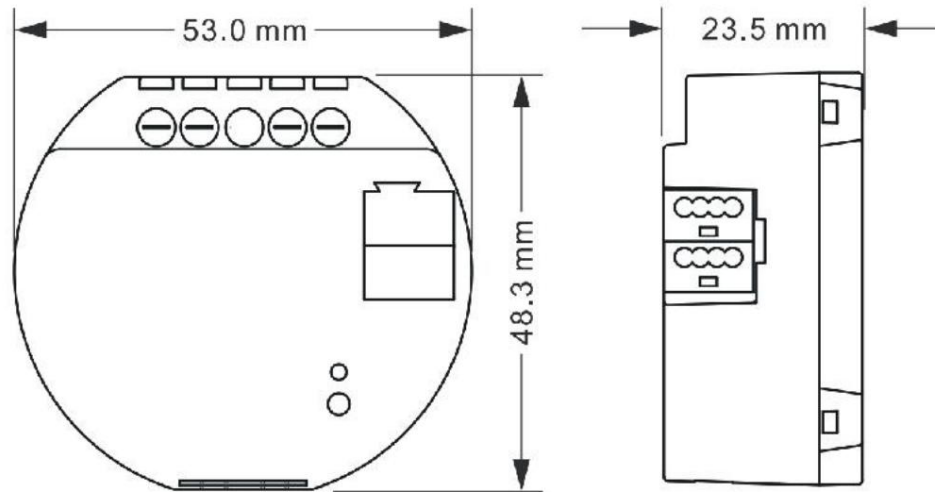

Fig.3.1(1) KNX Gateway for IR,Flush mounted,2-Fold (BTIRF-02/00.2)

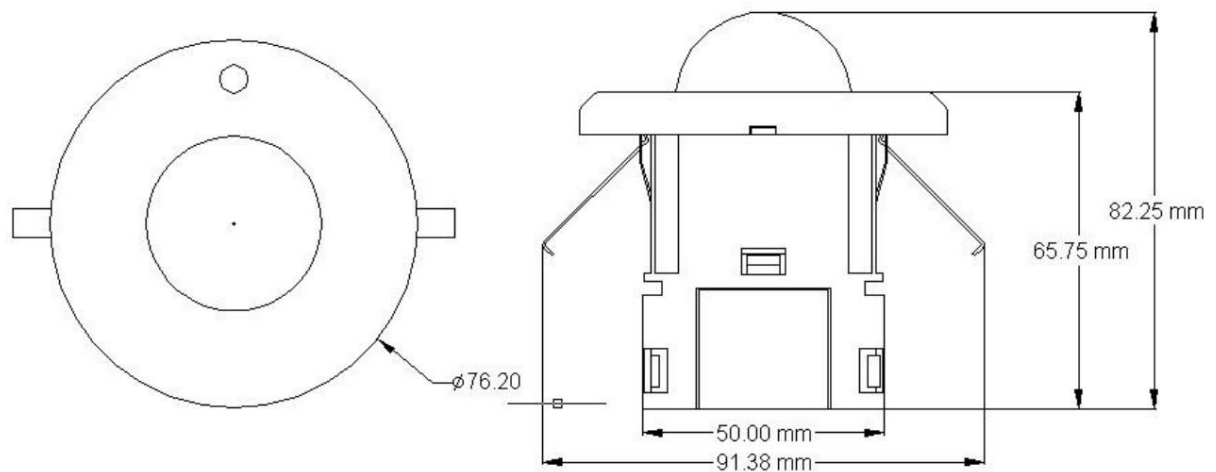

Fig.3.1(2) KNX Gateway for IR,Ceiling (BTIRC-01/00.2)

3.2 Connection diagram

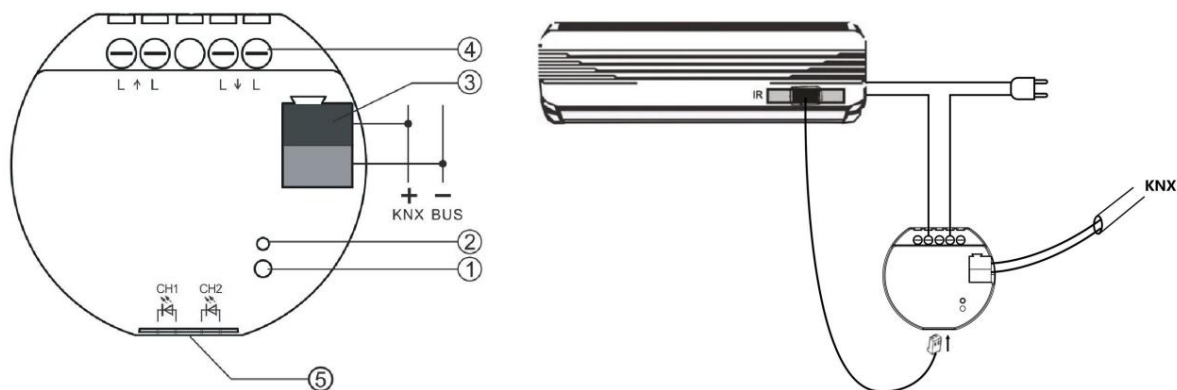

Fig.3.2(1) KNX Gateway for IR, Flush mounted, 2-Fold (BTIRF-02/00.2)

- Programming LED
- Programming button
- KNX bus connection terminal
- Device load connection terminals, if require current detection
- Connectors for Infrared emitter cable

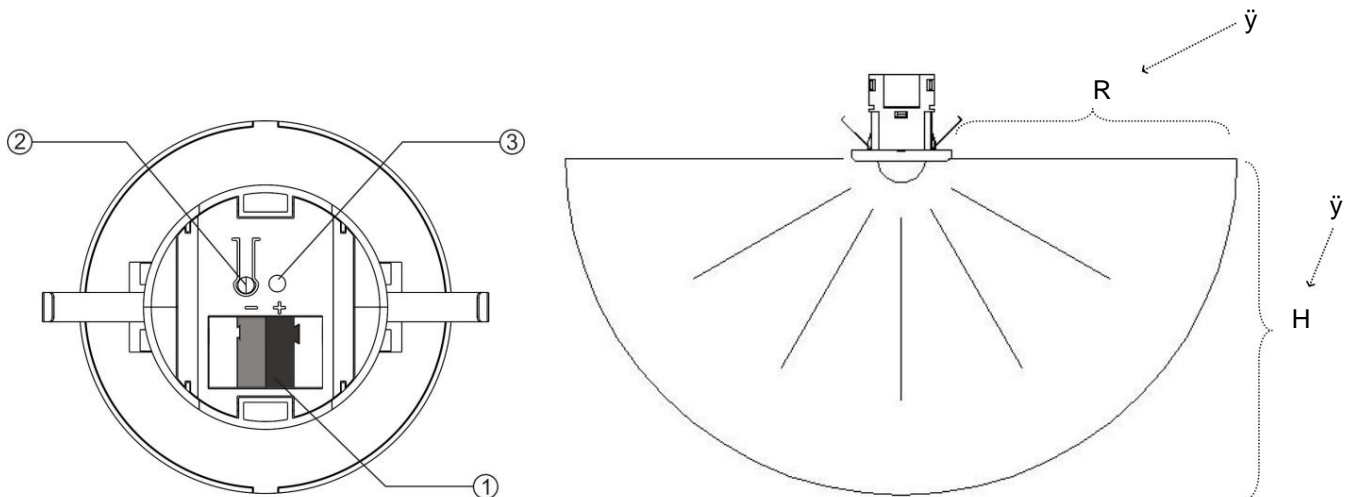

Fig.3.2(2) KNX Gateway for IR, Ceiling (BTIRC-01/00.2)

- KNX bus connection terminal
- Programming button
- Programming LED
- Installation height: <4m
- Transmit radius: <3m

Chapter 4 Project design and Application

| Application | Max.number of communication objects | Max. Number of group address | Max. number of associations |
|---|-------------------------------------|------------------------------|-----------------------------|
| KNX Gateway for IR, Flush mounted, 2-Fold/1.0 KNX Gateway for IR,Ceiling/1.0 | 167 | 500 | 500 |

General Setting

General setting includes device In operation setting and channel function setting. In operation setting is used for indicating whether the device application layer running normally. Channel function can be configured Universal IR control or Air-condition control, up to set 2 channels. But only one of the channels is supported to Air condition control. That is when Channel 1 is used for Air-condition control, and Channel 2 is only used for Universal IR control; if Channel 1 is used for Universal IR control, and Channel 2 can be used for Air-condition control.

universal IR control

Each channel up to support 30 IR code configurations is used for universal control, such as Fan, TV, DVD and etc. You can set the object datatype 1bit or 1byte, the object value, the corresponding IR code, and the status feedback to trigger the IR code to emit. Each IR code can set emission time and sending count.

In addition, KNX Gateway for IR,Flush mounted also supports whether to connect with current detection status, and you can decide whether to emit IR code according to the current switch status after connecting.

Air condition device control

Support the similar control way of universal Air-condition gateway, which is built-in status save and logic operation, can be controlled independently;

Support the function control and the status feedback: Air-condition switch, setpoint temperature, modes, fan speed, and swing;



Set the connection with the window sensor, turn off Air-condition after delay a time when it receives the window open command, to save energy;

Set the connection with the presence sensor, turn off Air-condition after delay a time when it receives the room unoccupied command, to save energy.

Sequence sending function

Up to support 16 sequence controls. Each sequence supports 1 bit or 1byte scene value trigger, up to support 4 IR commands binding sent, and each command can be set the delay time, the count and the channel of emission.

Current function(Only the Flush mounted support)

Supports a current detection function of up to 10A, can be connected with emission channel. Users can set the setpoint current threshold value (decided by the technology for the load), to define the power on/off status of controlled device. Current detection value and switch status can be both sent to the bus.

Chapter 5 Parameter setting description in the ETS

This chapter takes KNX Gateway for IR, Flush mounted, 2-Fold as example to explain the ETS system parameter setting of KNX gateway for IR. And the Ceiling and the Flush mounted are mainly different in without current detection function.

5.1 Parameter window “DCA Note”

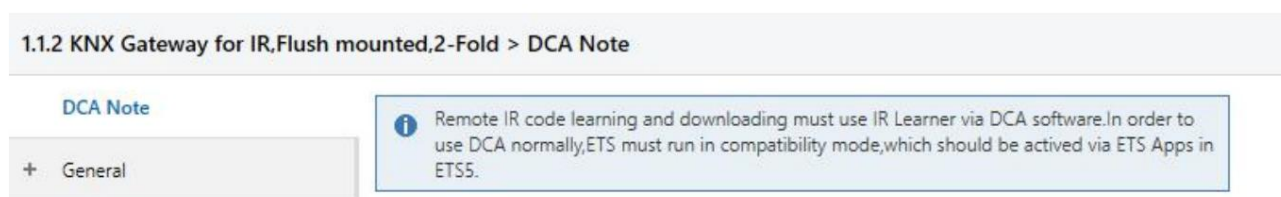
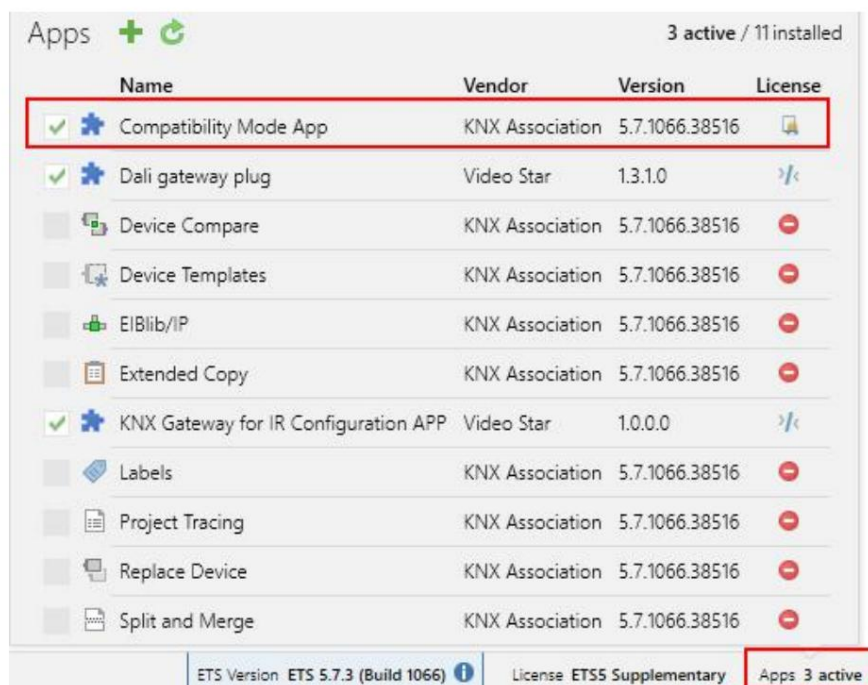

Fig.5.1 “DCA Note” parameter window

A noting message. Remote IR code learning and downloading must use IR Learner via DCA software, you can download the DCA form MyKNX online shop or get it from the manufacture. In order to use DCA normally, ETS must run in compatibility mode, which should be activated via ETS Apps window in ETS5, as shown as follow figure.



5.2 Parameter window “General setting”

--- KNX Gateway for IR, Flush mounted, 2-Fold > General > General setting

DCA Note

Send cycle of "In operation" telegram [1..240,0=inactive] 0 min

General

General setting

Channel 1

Channel 2

Sequence mode

Current detect

Channel setting

Channel 1 function Universal IR control

Check current status when emitting External

Monitoring period of current ON/OFF [0..255,0=inactive] 0 min

Channel 2 function Air-condition control

Function setting

Sequence mode function

Current detection function

Fig.5.2 "General setting" parameter window

Parameter "Send cycle of "In operation" telegram [1 ...240s, 0 = inactive]"

This parameter is for setting the time interval when this module cycle send telegrams through the bus to indicate this module in normal operation. When set to "0", the object "in operation" will not send a telegram. if the setting is not "0", the object "In operation" will send a telegram according to the set period time with logic "1" to the bus. Options: **0...240s, 0= inactive**

As to reduce the bus load as much as possible, the maximum time interval should be selected according to current needs.

channel setting

Parameter "Channel x function"(x=1, 2)

This parameter is for setting the channel function of KNX gateway for IR. Options:

- disable**
- universal IR control**
- air condition control**

Note: When channel 1 is set as Air-condition control, and channel 2 is only set as Universal IR control;

If channel 1 is set as Universal IR control, and channel 2 can be set as Air-condition control or Universal IR control.

Parameter "Check current status when emitting"

This parameter is visible when channel function is selected as "Universal IR control". Set whether to connect with current detection status. It decides the On or Off status of the controlled device according to the current status, to avoid false triggering when the same IR code is used for On and Off. If On and Off use different IR codes to control, no need to set connection. Options:

disable

Local

External

Disable: No connection;

Local: local connection, the device's own current detection function is used;

External: external connection, give the current status of external device detection to the device.

—Parameter "Monitoring period of current ON/OFF [0..255,0=inactive]min"

This parameter is visible when current detection status is selected as "External". Set the monitoring period of external current switch status. If current switch status from the external device is not received during monitoring period, wrong current detection of external will be considered.

Options: **0..255, 0=inactive**

—Parameter "Reply error of current detection"

This parameter is visible when the monitoring period>0. When external current detection is error, set whether to send error telegram to the bus. Sent when status changes. Options:

None

0=no error/1=error

1=no error/0=error

None: no sending.

0=no error/1=error: when error, object "CHx-External error report" sends telegram "1" to the bus, and no error sends "0";

1=no error/0=error: when error, object "CHx-External error report" sends telegram "0" to the bus, and no error sends "1".

Function setting

Parameter "Sequence mode function"

This parameter is for setting whether to enable sequence mode function, display the relevant window after selected.

Parameter "Current detection function"

This parameter is for setting whether to enable current detection function, display the relevant window after selected.

5.3 Parameter window "Channel x" (x=1, 2)

5.3.1. Parameter window "Universal IR control setting"

| IR control | Status |
|--------------|--------|
| IR control 1 | ✓ |
| IR control 2 | ✓ |
| IR control 3 | ✓ |
| IR control 4 | ✓ |
| IR control 5 | ✓ |
| IR control 6 | ✓ |
| IR control 7 | ✓ |

Fig.5.3.1(1) "Universal IR control setting" parameter window

| | |
|---|---|
| Description (max 30char.) | <input type="text"/> |
| Object datatype of trigger value | <input type="radio"/> 1bit [On/Off] <input checked="" type="radio"/> 1byte [0..255] |
| Trigger value | <input type="text" value="0"/> |
| Assign an IR code NO. | <input type="text" value="1"/> |
| Delay time for emitting [0..255] | <input type="text" value="0"/> *0.1s |
| Count of emitting [1..100] | <input type="text" value="1"/> |
| Emitting IR code when current status is | <input type="text" value="1 [On]"/> |
| Status response | <input type="text" value="No"/> |

Fig.5.3.1(2) "IR control x" parameter window

Parameter "IR control x"(x=1-30)

This parameter is for setting whether to enable IR control, display the relevant window after selected. each channel up to support 30 IR controls.

Parameter "Description (max 30char.)"

This parameter is for setting the custom description of IR code, and the description of corresponding setting window and object name will also change. Up to 30 characters can be input.

Parameter "Object datatype of trigger value"

This parameter is for setting the object datatype for triggering the IR code emit. Options:

1bit [On/Off]

1byte [0..255]

—Parameter "Trigger value"

This parameter is for setting the received value when IR code emission is triggered. The value is based on the trigger object datatype:

When select 1 bit, options:

1 [On]

0 [Off]

Both 1 and 0

When select 1byte, options: **0..255**

Parameter "Assign an IR code NO.[1..300]"

This parameter is for setting the emitted IR code, with a total selection of 300 IR codes. Options: **1,300**

Parameter "Delay time for emitting [0..255]*0.1s"

This parameter is for setting the delay time of IR code emission. Options: **0..255**

Parameter "Count of emitting [1..100]"

This parameter is for setting the count of IR code emission. Options: **1..100**

Parameter "Emitting IR code when current status is"

This parameter is visible when the current detection status is selected "Local" or "External". Set whether to emit IR code according to the current status. Options:

1 [On]

0 [Off]

Both 1 and 0

1 [On]: if current status is ON, emit IR code, otherwise not.

0 [Off]: if current status is OFF, emit IR code, otherwise not.

Both 1 and 0: both emit when the current status is On or Off.

Parameter "Status response"

This parameter is for setting whether to reply a status value to the bus after the device emitting IR code, to inform emission is completed. Options:

At the

Response value '1'

Response value '0'

According to control value

No: not responding;

Response value '1': object "IR Response value" replies the telegram value "1";

Response value '0': object "IR Response value" replies the telegram value "0";

According control value: object "IR Response value" the telegram value of response is the same as trigger value.

5.3.2. Parameter window “Air-condition control setting”

--- KNX Gateway for IR, Flush mounted, 2-Fold > Channel 1 > Air-condition control

| | | |
|------------------------------|--|---|
| DCA Note | Remote model NO. | 0 |
| + General | ✘ Remote model NO. do not support currently | |
| - Channel 1 | Description (max 30char.) | |
| Air-condition control | Assign IR code NO. for OFF | 265 |
| + Channel 2 | Assign IR code NO. for ON | 266 |
| + Sequence mode | Initial configuration for ON | |
| + Current detect | Temperature | 25 °C |
| | Mode | Auto |
| | Fan speed | Auto |
| | Swing | <input type="radio"/> Swing <input checked="" type="radio"/> Stop |
| | Object datatype of setpoint temperature | <input type="radio"/> 1byte (real temperature value) <input checked="" type="radio"/> 2byte (knx standard DPT) |
| | Min. setpoint temperature | 16 °C |
| | Max. setpoint temperature | 30 °C |
| | Emitting AC status after bus recovery | No |
| | AC status response object | <input type="radio"/> Disable <input checked="" type="radio"/> Enable |
| | Window sensor | <input type="radio"/> Disable <input checked="" type="radio"/> Enable |
| | Delay to turn off AC after window open [0..255] | 1 min |
| | Presence detector | <input type="radio"/> Disable <input checked="" type="radio"/> Enable |
| | Delay to turn off AC after the room unoccupied [0..255] | 20 min |
| | Object datatype of 1byte fan speed | <input type="radio"/> Fan stage (DPT_5.100) <input checked="" type="radio"/> Percentage (DPT_5.001) |
| | Fan speed control setting | |
| Heat-Fan auto-No Swing | Control value for fan speed auto | 0 % |
| Heat-Fan low-No Swing | Control value for fan speed low | 33 % |
| Heat-Fan medium-No Swing | Control value for fan speed medium | 67 % |
| Heat-Fan high-No Swing | Control value for fan speed high | 100 % |
| Heat-Fan auto-Swing | Fan speed status setting | |
| Heat-Fan low-Swing | Status value for fan speed auto | 0 % |
| Heat-Fan medium-Swing | Status value for fan speed low | 33 % |
| Heat-Fan high-Swing | Status value for fan speed medium | 67 % |
| Cool-Fan auto-No Swing | Status value for fan speed high | 100 % |
| Cool-Fan low-No Swing | | |
| Cool-Fan medium-No Swing | | |
| Cool-Fan high-No Swing | | |

Fig.5.3.2(1) “Air-condition control setting” parameter window

| Heat-Fan medium-No Swing | Swing control | <input type="radio"/> Disable <input checked="" type="radio"/> Enable |
|--------------------------------|---|---|
| Heat-Fan high-No Swing | Mode control function | |
| Heat-Fan auto-Swing | Auto mode | <input checked="" type="checkbox"/> |
| Heat-Fan low-Swing | Control value for auto [0..255] | 0 |
| Heat-Fan medium-Swing | Status value for auto [0..255] | 0 |
| Heat-Fan high-Swing | Heating mode | <input checked="" type="checkbox"/> |
| Cool-Fan auto-No Swing | Control value for heating [0..255] | 1 |
| Cool-Fan low-No Swing | Status value for heating [0..255] | 1 |
| Cool-Fan medium-No Swing | Cooling mode | <input checked="" type="checkbox"/> |
| Cool-Fan high-No Swing | Control value for cooling [0..255] | 3 |
| Cool-Fan auto-Swing | Status value for cooling [0..255] | 3 |
| Cool-Fan low-Swing | Fan mode | <input checked="" type="checkbox"/> |
| Cool-Fan medium-Swing | Control value for fan [0..255] | 9 |
| Cool-Fan high-Swing | Status value for fan [0..255] | 9 |
| Fan-Fan speed-Wind | Dehumidification mode | <input checked="" type="checkbox"/> |
| Dehumidification-Fan speed-... | Control value for dehumidification [0..255] | 14 |
| | Status value for dehumidification [0..255] | 14 |

Fig.5.3.2(2) "Air-condition control setting" parameter window

Parameter "Remote model NO."

This parameter is for setting the remote model number of Air-condition. Options: **0..255**

Note: This parameter is a preset parameter. Do not support to input remote model number currently.

Parameter "Description (max 30char.)"

This parameter is for setting the custom description of Air-condition, and the description of corresponding object name of Air-condition will also change. Up to 30 characters can be input.

Parameter "Assign IR code NO. for OFF [1..300]"

This parameter is for setting the IR code number when power off Air-condition. Options: **1,300**

Parameter "Assign IR code NO. for ON [1..300]"

This parameter is for setting the IR code number when power on Air-condition. Options: **1,300**

Initial configuration for ON

Note: If the configuration of the initial status is not consistent with the IR code learned by ON, there will be inconsistencies in the status of the realized control and the feedback from the device to the bus. The control is controlled by the IR code and the feedback is fed back according to the configuration of the initial status.

The following parameters are for setting the initial status when power on Air-condition.

Parameter "Temperature"

This parameter is for setting the temperature of Air-condition when power on. Options:

16°C

17°C

...

30°C

Parameter "Mode"

This parameter is for setting the control mode of Air-condition when power on. Options:

Heating

Cooling

Dehumidification

fan

Self

Parameter "Fan speed"

This parameter is for setting the fan speed of Air-condition when power on. Options:

Self

Low

Medium

High

Parameter "Swing"

This parameter is visible when enable swing control. Set the action of swing when power on. Options:

swing

stop

Parameter "Object datatype of setpoint temperature"

This parameter is for setting object datatype of setpoint temperature. Options:

1byte (actual temperature value)

2byte (knx standard DPT)

Parameter "Min. setpoint temperature"**Parameter "Max. setpoint temperature"**

These two parameters are for setting the adjustable range for limiting the temperature setpoint value. The minimum value must be less than the maximum value. If the setpoint value exceeds the limited range, output according to the limit. Options:

16°C

17°C

...

30°C

Parameter "Emitting AC status after bus recovery"

This parameter is for setting whether to send the command of Air-condition control to the device after bus reset. Options:

At the

On

Off

As before power off

No: no emission;

On: emit the IR code when power on Air-condition;

Off: emit the IR code when power off Air-condition;

As before power off: issue the IR code of the Air-condition status as before power off.

Parameter "AC status response object"

This parameter is for setting whether to enable the AC status response object. When enabled, the status objects of switch, fan speed, mode, setpoint temperature and swing are visible. And they will send initial status to the bus when bus power on. Options:

disable

enable

Parameter "Window sensor"

This parameter is for setting whether to enable connect with the sensor that detect the switch status of window. This is external sensor. Options:

disable

enable

—Parameter “Delay to turn off AC after window open [0..255]min”

This parameter is visible when the previous parameter is enabled. Set the delay time for turning off Air-condition when receive a command of opening window from sensor, to save energy. Options: **0..255**

Parameter “Presence detector”

This parameter is for setting whether to enable connect with the presence detector. This is external sensor.

Options:

disable

enable

—Parameter “Delay to turn off AC after the room unoccupied [0..255]min”

This parameter is visible when the previous parameter is enabled. Set the delay time for turning off Air-condition when receive command of the room unoccupied from sensor, to save energy. Options: **0..255**

Parameter “Object datatype of 1byte fan speed”

This parameter is for setting the object datatype of 1 byte fan speed. Options:

Fan stage (DPT_5,100)

Percentage (DPT_5.001)

Fan speed control setting**—Parameter “Control value for fan speed auto/low/medium/high/auto”**

These parameters are for setting the control values sent by each fan speed. According to object datatype, the range of control value: **0..255 / 0..100**

—Parameter “Status value for fan speed auto/low/medium/high/auto”

These parameters are for setting the status feedback values of each fan speed. According to object datatype, the range of control value: **0..255 / 0..100**

Parameter “Swing control”

This parameter is for setting whether to enable swing control. When enabled, relevant settings are visible.

Options:

disable

enable

mode control function

Parameter “Auto/Heating/Cooling/Fan/Dehumidification mode”

These parameters are for setting whether to enable each Air-condition mode. When enabled, relevant settings are visible.

——Parameter “Control value for heating/cooling/dehumidification/fan/auto mode [0..255]”

These parameters are visible when modes are enabled. Set to switch to each mode control value. Options: **0..255**

——Parameter “Status value for heating/cooling/dehumidification/fan/auto mode [0..255]”

These parameters are visible when modes enabled and “AC status response object” enabled. Set to the each mode status feedback value. Options: **0..255**

The following is mainly explain IR code number assignment of various combination control functions. in Air-condition control system, usually an IR code includes multiple control instructions, such as setpoint temperature, modes, fan speed, swing and etc. Therefore, it need configure IR code according to actual study when assign IR code for each combination control function in ETS. The study of IR code and related configuration can be edited or checked in configuration software tool or DCA, as following figure.

| Description | Function | Frequency | Pulse count | IR code NO. |
|-------------|---------------|-----------|-------------|-------------|
| DAIKIN | Cool-Auto-16° | 33.21KHZ | 327 | 21 |

Fig 5.3.2 (3) IR code library

The parameter setting windows of IR code number assignment of each combination control function are as following, take two of these windows as an example to explain. Auto/Fan/Dehumidification modes do not have adjustment of setpoint temperature, therefore, these three modes settings are similar. And Heat/Cool modes have setpoint temperature, so that these two modes settings are similar.

--- KNX Gateway for IR, Flush mounted, 2-Fold > Channel 1 > Auto-Fan speed-Wind

| | | |
|--------------------------|--------------------------------|----------------------|
| DCA Note | 1->Assign IR code NO. [1..300] | 1 |
| + General | Control function | Auto-Auto-No Swing |
| - Channel 1 | 2->Assign IR code NO. [1..300] | 2 |
| Air-condition control | Control function | Auto-Low-No Swing |
| Auto-Fan speed-Wind | 3->Assign IR code NO. [1..300] | 3 |
| Heat-Fan auto-No Swing | Control function | Auto-Medium-No Swing |
| Heat-Fan low-No Swing | 4->Assign IR code NO. [1..300] | 4 |
| Heat-Fan medium-No Swing | Control function | Auto-High-No Swing |
| | 5->Assign IR code NO. [1..300] | 5 |
| | Control function | Auto-Auto-Swing |

Fig.5.3.2(4) "Auto-Fan speed-Wind" parameter window

Parameter "1->Assign IR code NO. [1..300]"

This parameter is for setting the IR code number corresponding to the combination function. Options: **1,300**

Parameter "Control function"

This parameter notes the control function contained in this IR code. So that, we need to find the IR code number in the IR code library according to control function when the IR code number is assigned for previous parameter.

As shown in the window, Auto-Auto-No Swing indicates that the control function is auto mode-auto fan speed-no swing, the corresponding IR code number is 1.

--- KNX Gateway for IR, Flush mounted, 2-Fold > Channel 1 > Heat-Fan auto-No Swing

| | | |
|--------------------------|--------------------------------|------|
| DCA Note | 1->Assign IR code NO. [1..300] | 9 |
| + General | Temperature | 16°C |
| - Channel 1 | 2->Assign IR code NO. [1..300] | 10 |
| Air-condition control | Temperature | 17°C |
| Auto-Fan speed-Wind | 3->Assign IR code NO. [1..300] | 11 |
| Heat-Fan auto-No Swing | Temperature | 18°C |
| Heat-Fan low-No Swing | 4->Assign IR code NO. [1..300] | 12 |
| Heat-Fan medium-No Swing | Temperature | 19°C |
| Heat-Fan high-No Swing | 5->Assign IR code NO. [1..300] | 13 |
| Heat-Fan auto-Swing | Temperature | 20°C |
| Heat-Fan low-Swing | 6->Assign IR code NO. [1..300] | 14 |
| Heat-Fan medium-Swing | Temperature | 21°C |
| Heat-Fan high-Swing | 7->Assign IR code NO. [1..300] | 15 |
| | Temperature | 22°C |
| | 8->Assign IR code NO. [1..300] | 16 |
| | Temperature | 23°C |

Fig.5.3.2(4) "Heat-Fan auto-No Swing" parameter window

yy"1->Assign IR code NO. [1..300]"

This parameter is for setting the IR code number corresponding to the combination function at each setpoint temperature. Options: **1,300**

yy"Temperature"

This parameter notes the setpoint temperature contained in this IR code, but the control function is indicated in the title of the parameter window (view on the left side of parameter configuration window). So that, we need find IR code number in the IR code library according to control function and setpoint temperature when the IR code number is assigned for previous parameter.

As shown in the window, Heat-Fan auto-No Swing on the left side indicates that the control function is heat mode-auto fan speed-no swing, the IR code number corresponding to the setpoint temperature 16°C is 9.

5.4 Parameter window “Sequence mode setting”

--- KNX Gateway for IR, Flush mounted, 2-Fold > Sequence mode > Sequence mode setting

| | | | |
|-----------|------------------------|-------------------------------------|-------------------------------------|
| DCA Note | Sequence combination 1 | <input checked="" type="checkbox"/> | |
| + General | Sequence combination 2 | <input checked="" type="checkbox"/> | |
| | Sequence combination 3 | <input checked="" type="checkbox"/> | |
| | + Channel 1 | Sequence combination 4 | <input checked="" type="checkbox"/> |
| | + Channel 2 | Sequence combination 5 | <input checked="" type="checkbox"/> |
| | - Sequence mode | Sequence combination 6 | <input checked="" type="checkbox"/> |
| | Sequence mode setting | Sequence combination 7 | <input checked="" type="checkbox"/> |
| | Sequence combination 1 | Sequence combination 8 | <input checked="" type="checkbox"/> |
| | Sequence combination 2 | Sequence combination 9 | <input checked="" type="checkbox"/> |
| | Sequence combination 3 | Sequence combination 10 | <input checked="" type="checkbox"/> |
| | Sequence combination 4 | Sequence combination 11 | <input checked="" type="checkbox"/> |
| | Sequence combination 5 | Sequence combination 12 | <input checked="" type="checkbox"/> |
| | | Sequence combination 13 | <input checked="" type="checkbox"/> |
| | | Sequence combination 14 | <input checked="" type="checkbox"/> |
| | | Sequence combination 15 | <input checked="" type="checkbox"/> |
| | | Sequence combination 16 | <input checked="" type="checkbox"/> |

Fig.5.4(1) “Sequence mode setting” parameter window

--- KNX Gateway for IR, Flush mounted, 2-Fold > Sequence mode > Sequence combination 1

| | | |
|-----------|-------------------------------------|--|
| DCA Note | Description (max 30char.) | <input type="text"/> |
| + General | Object datatype of trigger sequence | <input checked="" type="radio"/> 1bit [On/Off] <input type="radio"/> 1byte [Scene No.] |
| | Trigger value | 1 [On] ▼ |
| | Enable step 1 command | <input type="radio"/> Disable <input checked="" type="radio"/> Enable |
| | IR code NO. for emitting [1..300] | 1 ▲▼ |
| | Emitting channel | <input checked="" type="radio"/> CH1 <input type="radio"/> CH2 |
| | Delay time for emitting [0..255] | 0 ▲▼ *0.1s |
| | Count of emitting [1..100] | 1 ▲▼ |
| | Enable step 2 command | <input type="radio"/> Disable <input checked="" type="radio"/> Enable |
| | IR code NO. for emitting [1..300] | 2 ▲▼ |
| | Emitting channel | <input checked="" type="radio"/> CH1 <input type="radio"/> CH2 |
| | Delay time for emitting [0..255] | 1 ▲▼ *0.1s |
| | Count of emitting [1..100] | 1 ▲▼ |

Fig.5.4(2) “Sequence combination 1” parameter window

Parameter “Sequence combination 1”(x=1-16)

This parameter is for setting whether to enable sequence combination control function, display related setting windows after selected. Up to support 16 sequence combination controls.

A sequence up to support 4 command settings. For example, a remote control fan, we can set a delay time for the command to execute gradually. The first step is power on, the second is adjust fan speed, the third is setting a swing, the fourth is setting a timing.

Parameter "Description (max 30char.)"

This parameter is for setting the custom description of sequence, and the description of corresponding object name of sequence will also change. Up to 30 characters can be input.

Parameter "Object datatype of trigger sequence"

This parameter is for setting the object datatype to trigger the sequence execution. Options:

1bit [On/Off]

1byte [Scene No.]

—Parameter "Trigger value"

This parameter is for setting the received value that trigger sequence execution. The value is according to the object datatype of trigger:

When select 1 bit, options:

1 [On]

0 [Off]

Both 1 and 0

When select 1 byte, options:

Scene No.1

...

Scene No.64

Parameter "Enable step x command"(x=1~4)

This parameter is for setting whether to enable command x(x=1~4). The setting of command x is visible when enabled. Options:

disable

enable



—Parameter “IR code NO. for emitting [1..300]”

This parameter is for setting the emission IR code of command x, which is configured by configuration software tool or DCA. Options: **1,300**

—Parameter “Emitting channel”

This parameter is for setting the emission channel connected with command x. Options:

CH1

CH2

—Parameter “Delay time for emitting [0..255]*0.1s”

This parameter is for setting the delay time for command x emitting IR code. Options: **0..255**

—Parameter “Count of emitting [1..100]”

This parameter is for setting the count for command x emitting IR code. Options: **1..100**

5.5 Parameter window “Current detect setting”

Note: Only the Flush mounted supports current detection function, and the Ceiling does not display this window.

Fig.5.5 “Current detect setting” parameter window

Internal current detect setting

Parameter “Object datatype of current detection”

This parameter is for setting the object datatype of current detection value. Options:

Value in mA (DPT 7.012)

Float Value in mA (DPT 9.021)

Value in mA(DPT 7.012): the unit of output current value is mA, integer data.

Float Value in mA(DPT 9.021): the unit of output current value is mA, float data.

Parameter “Send current value”

This parameter is for setting whether to send current detection value, or setting the sending conditions.

Current value is sent to the bus by the object “Current value(mA)”. Options:

No send

send on change

Send cyclically

Send on read only

—Parameter “Value send after the changed [1..2000]mA”

This parameter is visible when selecting “Send on change”. Set the change value that sending current detection

value should be reached. Options: **1..2000**

For example, set 50mA. When the current value is 100mA, it needs that the current current value is more than 150mA or less than 50mA can send the current value to the bus.

—Parameter “ **Period of cyclical send [10..50000]s**”

This parameter is visible when selecting “Send cyclically”. Set the time period that cyclically sending current detection value. Options: **10..50000**

Parameter “ **Current threshold for ON [100..2000]mA**”

This parameter is for setting the current threshold for power on. The device status is On when the current is greater than or equal to the value. Options: **100..2000**

Parameter “ **Hysteresis value [0..50]mA**”

This parameter is for setting the hysteresis value. The device status is Off when current value less than (threshold - hysteresis value), no action in the interval. No hysteresis when the value is 0. Options: **0..50**

Parameter “ **Send switch status**”

This parameter is for setting whether to send switch status, and setting the sending conditions. switch status is sent to the bus by the object “Switch ON/OFF” Options:

No send

send on change

Send cyclically

Send on read only

—Parameter “ **Period of cyclical send [10..50000]s**”

This parameter is visible when selecting “Send cyclically”. Set the time period that cyclically sending switch status. Options: **10..50000**

Chapter 6 Communication Object Description

The communication object is the medium through which the device communicates with other devices on the bus, that is, only the communication object can perform bus communication.

The function of each communication object of each function block is described in detail below.

Note: “C” in the property bar of the table below represents the communication function of the communication object;

“W” represents the value of the communication object can be rewritten by the bus;

“R” represents the value of the communication object can be read through the bus;

“T” stands for communication object with transmission function;

“U” means that the value of the communication object can be updated.

6.1 “General setting” communication object

| Number | Name | Object Function | Description | Group Address | Length | C | R | W | T | U | Data Type | Priority |
|--------|---------|-----------------|-------------|---------------|--------|---|---|---|---|---|-----------|----------|
| 1 | General | In operation | | | 1 bit | C | - | - | T | - | switch | Low |

Fig.6.1 “General” communication object

| AT THE | ObjectFunction | Name | Date | Type | Flag | DPT |
|--------|----------------|---------|------|------|-------|---------------|
| 1 | In operation | General | | 1bit | C,R,T | 1001 switches |

This communication object is used to periodically send a telegram “1” to the bus to indicate that the device is working properly.

Table 6.1 “General setting ” communication object

6.2 “Universal IR code control” communication object

| Number | Name | Object Function | Description | Group Address | Length | C | R | W | T | U | Data Type | Priority |
|--------|--------------------------|--------------------------|-------------|---------------|--------|---|---|---|---|---|-------------------------|----------|
| 18 | CH1-IR control 1: Input | IR Control trigger value | | | 1 byte | C | - | W | - | U | counter pulses (0..255) | Low |
| 19 | CH1-IR control 1: Status | IR Response value | | | 1 byte | C | R | - | T | - | counter pulses (0..255) | Low |

Fig.6.2 “Universal IR code control” communication object

| AT THE | ObjectFunction | Name | Date Type | Flag | DPT |
|---|--------------------------|------------------------------|---------------|-------|---------------------------------------|
| 18 | IR Control trigger value | CH1-{{IR control 1}}: Input | 1bit 1byte | C,W,U | 1001 switches 5,010 counter pulses |
| <p>This communication object is used to receive trigger value of IR code. Object datatype and trigger telegram are both set by parameter.</p> <p>The name in parentheses{{}} changes with the parameter “Description (max 30 char.)”. If description is empty, display “...IR control x...” by default, such as “CH1-IR control 1: Input”. Below is the same.</p> | | | | | |
| 19 | IR Response value | CH1-{{IR control 1}}: Status | 1bit 1byte | C,R,T | 1001 switches 5,010 counter pulses |
| <p>This communication object is used to reply a status value to the bus after the device sending IR code, to inform emission is completed.</p> <p>Responding control value is set by parameter, object datatype is the same as trigger value's.</p> | | | | | |

Table 6.2 “Universal IR code control” communication object

6.3 “Air-condition control” communication object

| Number | Name | Object Function | Description | Group Address | Length | C | R | W | T | U | Data Type | Priority |
|--------|----------------|------------------------------|-------------|---------------|---------|---|---|---|---|---|----------------------|----------|
| 78 | CH1-AC: Input | Power on/off | | | 1 bit | C | - | W | - | U | switch | Low |
| 79 | CH1-AC: Input | Current setpoint adjustment | | | 2 bytes | C | - | W | - | U | temperature (°C) | Low |
| 80 | CH1-AC: Input | Control mode | | | 1 byte | C | - | W | - | U | HVAC control mode | Low |
| 81 | CH1-AC: Input | Fan speed | | | 1 byte | C | - | W | - | U | percentage (0..100%) | Low |
| 82 | CH1-AC: Input | Wind swing=1/stop=0 | | | 1 bit | C | - | W | - | U | trigger | Low |
| 83 | CH1-AC: Input | Window contact | | | 1 bit | C | - | W | - | U | window/door | Low |
| 84 | CH1-AC: Input | Presence detector | | | 1 bit | C | - | W | - | U | occupancy | Low |
| 85 | CH1-AC: Status | Power on/off | | | 1 bit | C | R | - | T | - | switch | Low |
| 86 | CH1-AC: Status | Current temperature setpoint | | | 2 bytes | C | R | - | T | - | temperature (°C) | Low |
| 87 | CH1-AC: Status | Control mode | | | 1 byte | C | R | - | T | - | HVAC control mode | Low |
| 88 | CH1-AC: Status | Fan speed | | | 1 byte | C | R | - | T | - | percentage (0..100%) | Low |
| 89 | CH1-AC: Status | Wind swing=1/stop=0 | | | 1 bit | C | R | - | T | - | trigger | Low |

Fig.6.3 “Air-condition control” communication object

| AT THE | ObjectFunction | Name | Date Type | Flag | DPT |
|---|-----------------------------|-------------------|----------------|-------|--|
| 78 | Power on/off | CH1-{{AC}}: Input | 1bit | C,W,U | 1001 switch |
| <p>This communication object is used to control switch status of Air-condition via the bus.</p> <p>Telegram value: 1—On/0—Off</p> <p>The name in parentheses{{}} changes with the parameter “Description (max 30 char.)”. If description is empty, display “...AC...” by default. Below is the same.</p> | | | | | |
| 79 | Current setpoint adjustment | CH1-{{AC}}: Input | 1byte 2byte | C,W,U | 5,010 counter pulses 9001 temperature |
| <p>This communication object is used to modify current setpoint temperature of Air-condition.</p> <p>Note: the object type is set by parameters, 2byte is suitable for KNX standard, 1byte is KNX non-standard, usually suitable for some custom control classes, the telegram value is the actual temperature value, such as 17 °C telegram value is 17 (decimal number).</p> | | | | | |
| 80 | control mode | CH1-{{AC}}: Input | 1byte | C,W,U | 20105 HVAC control mode |
| <p>This communication object is used to control each mode of Air-condition via bus.</p> | | | | | |
| 81 | fan speed | CH1-{{AC}}: Input | 1byte | C,W,U | 5,001 percentage 5,100 fan stages |
| <p>This communication object is used to control fan speed of Air-condition via bus. Object datatype is set by parameter.</p> | | | | | |
| 82 | Wind swing=1/stop=0 | CH1-{{AC}}: Input | 1bit | C,W,U | 1017 trigger |
| <p>This communication object is used to control swing of Air-condition via bus.</p> <p>Telegram value: 0—Stop /1—Swing</p> | | | | | |

| | | | | | |
|--|-------------------------------|--------------------|----------------|-------------|--|
| 83 | window contact | CH1-{{AC}}: Input | 1bit | C,W,U 1.019 | window/door |
| This communication object is used to receive the switch status of window contact. | | | | | |
| 84 | presence detector | CH1-{{AC}}: Input | 1bit | C,W,U 1.018 | occupation |
| This communication object is used to receive the room occupied status of presence detector. | | | | | |
| 85 | Power on/off | CH1-{{AC}}: Status | 1bit | C,R,T | 1001 switches |
| This communication object is used to feedback the switch status of Air-condition to bus. Telegram value: 1—On/0—Off | | | | | |
| 86 | Current temperature set point | CH1-{{AC}}: Status | 1byte 2byte | C,R,T | 5,010 counter pulses 9001 temperature |
| This communication object is used to feedback actual setpoint temperature value of Air-condition to the bus. Object datatype is set by parameter. | | | | | |
| 87 | control mode | CH1-{{AC}}: Status | 1byte | C,R,T | 20.105 HVAC control mode |
| This communication object is used to send the control telegram of each mode of Air-condition to bus. | | | | | |
| 88 | fan speed | CH1-{{AC}}: Status | 1byte | C,R,T | 5,010 counter pulses 9001 temperature |
| The communication object is used to feedback current fan speed status of Air-condition to bus. | | | | | |
| 89 | Wind swing=1/stop=0 | CH1-{{AC}}: Status | 1bit | C,R,T | 1017 trigger |
| The communication object is used to feedback wind swing status of Air-condition to bus. Telegram value: 0—stop/1—swing | | | | | |

Table 6.2 "Air-condition control" communication object

6.4 “Sequence mode” communication object

| Number ^ | Name | Object Function | Description | Group Address | Length | C | R | W | T | U | Data Type | Priority |
|----------|------------|------------------------|-------------|---------------|--------|---|---|---|---|---|-----------|----------|
| 2 | Sequence 1 | Sequence trigger value | | | 1 bit | C | - | W | - | U | switch | Low |

Fig.6.4 “Sequence mode” communication object

| AT THE. | ObjectFunction | Name | Date Type | Flag | DPT |
|---------|------------------------|----------------|-----------|-------|---------------------|
| | Sequence trigger value | {{Sequence 1}} | 1bit | | 1001 switches |
| | | | 1byte | C,W,U | 17,001 scene number |

This communication object is used to receive the sequence trigger value from the bus. Object datatype is set by parameter.

The name in parentheses{{}} changes with the parameter “Description (max 30 char.)”. If description is empty, display “Sequence x” by default.

Table 6.4 “Sequence mode” communication object

6.5 “Current detect” communication object

| Number ^ | Name | Object Function | Description | Group Address | Length | C | R | W | T | U | Data Type | Priority |
|----------|-------------------|----------------------------|-------------|---------------|---------|---|---|---|---|---|--------------|----------|
| 162 | Current detection | Switch ON/OFF | | | 1 bit | C | R | - | T | - | switch | Low |
| 163 | Current detection | Current value(mA) | | | 2 bytes | C | R | - | T | - | current (mA) | Low |
| 164 | Current detection | CH1-External switch ON/OFF | | | 1 bit | C | - | W | - | U | switch | Low |
| 165 | Current detection | CH1-External error report | | | 1 bit | C | R | - | T | - | alarm | Low |
| 166 | Current detection | CH2-External switch ON/OFF | | | 1 bit | C | - | W | - | U | switch | Low |
| 167 | Current detection | CH2-External error report | | | 1 bit | C | R | - | T | - | alarm | Low |

Fig.6.5 “Current detect” communication object

| AT THE. | ObjectFunction | Name | Date Type | Flag | DPT |
|---------|----------------|-------------------|-----------|-------|---------------|
| 162 | Switch ON/OFF | Current detection | 1bit | C,R,T | 1001 switches |

This communication object is used to send switch status of the device current detection to bus.

| AT THE. | ObjectFunction | Name | Date Type | Flag | DPT |
|---------|-------------------|-------------------|-----------|-------|--|
| 163 | Current value(mA) | Current detection | 2byte | C,R,T | 7,012 current (mA) 9,021 current (mA) |

This communication object is used to send current value of detection to bus. Object datatype is set by parameter.

| AT THE. | ObjectFunction | Name | Date Type | Flag | DPT |
|---------|----------------------------|-------------------|-----------|-------|-------------|
| 164 | CH1-External switch ON/OFF | Current detection | 1bit | C,W,U | 1001 switch |

This communication object is visible when channel 1 is connected with external current detection. Used to receive the current status that the current detection device detects from the bus (On/Off).



| | | | |
|---|--------------------------|-------------|--------------------------|
| 165 CH1-External error report | Current detection | 1bit | C,R,T 1.005 alarm |
| This communication object is used to send external current detection error telegram of channel 1. | | | |
| 166 CH2-External switch ON/OFF Current detection | | 1bit | C,W,U 1001 switch |
| This communication object is visible when channel 1 is connected with external current detection. Used to receive the current status that the current detection device detects from the bus (On/Off). | | | |
| 167 CH2-External switch ON/OFF Current detection | | 1bit | C,R,T 1.005 alarm |
| This communication object is used to send external current detection error report of channel 2. | | | |

Table 6.5 "Current detect" communication object